

# FIBEROCK™ Brand Underlayment Installation Guide

*Everywhere, every floor.™*



**Underlayment installation for vinyl, ceramic tile, carpeting, laminate and hardwood flooring.**

## FIBEROCK™ Brand Underlayment – For all the floors in your home

FIBEROCK™ Brand Underlayment—AQUA-TOUGH™ is the all-purpose substrate engineered to meet every underlayment need throughout your entire home. Under ceramic tile, it provides the water-resistance needed to stand up to use in bathrooms, kitchens, and entryways. Under vinyl, carpeting, laminate flooring, and hardwood flooring, it offers a smooth, flat, tough surface with no bumps or ridges to show through your flooring. That means that you can now rely on a single underlayment product for use throughout your entire home—in both wet and dry areas—regardless of the flooring materials chosen.

This remarkable new product is completely different from most commonly used wood-based substrates. Manufactured from a specially treated combination of gypsum and cellulose fibers, FIBEROCK Brand AQUA-TOUGH Underlayment has a tough, uniform, water-resistant composition that helps prevent the problems typically associated with plywood, oriented strand board (OSB), and lauan underlayments. FIBEROCK Brand Underlayment provides a smooth, flat surface, with no bumps or ridges to telegraph through. It resists the swelling and warping often seen with wood-based products, and contains none of the resins, adhesives, solvents, or dyes that can stain floor covering materials. FIBEROCK Brand Underlayment also has a special coating that ensures proper workability and bonding of floor-covering adhesives.

FIBEROCK Brand Underlayment is truly the ideal substrate for all your floors, both today and tomorrow. Today, it offers added convenience, because it's an all-purpose product that eliminates the need to switch substrates when you change floor coverings. Tomorrow, it provides peace of mind, because it protects your beautiful new floor coverings against indentation, warping, staining, and show-through. That means your new floors will continue looking great, year after year—throughout your entire home.

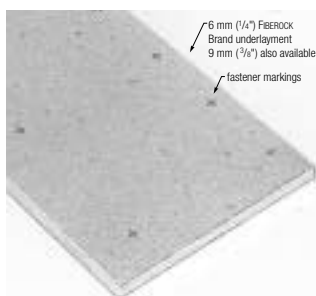

To provide you with even more assurance, FIBEROCK Brand Underlayment is warranted for 15 years against buckling, warping, delamination, cracking, and splitting upon fastening. It is also an environmentally friendly product (unlike many wood-based underlayments, which may use endangered and old-growth trees.) FIBEROCK Brand Underlayment has been tested by the Tile Council of America (using the Robinson Floor Test Method).

## Introduction

Installing FIBEROCK Brand Underlayment is quick and easy. Just follow the simple steps below to create a perfect base for your floor covering. Do not use in wet areas (such as shower stalls, saunas, and hot tub decks); on concrete subfloors; over cushion-backed vinyl flooring, or perimeter-fastened vinyl.

## Tools

In general, common tools like those shown below are used to install FIBEROCK Brand Underlayment. Specialized tools may be required for working with some floorings, such as ceramic tile. Consult the instructions provided by your floor-covering manufacturer for specific tools and procedures.

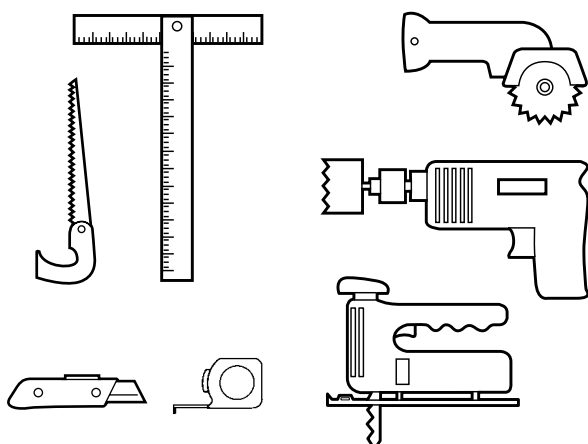

## Storage

- Protect panels from the elements with adequate covering during delivery and storage.
- Store panels flat on an even, dry surface. Allow them to acclimate to job site conditions for 48 hours prior to installation.
- Handle panels in an upright position to prevent breakage.

### Correct

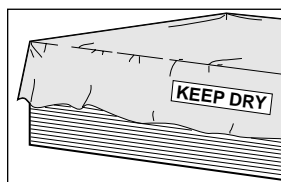

### Incorrect

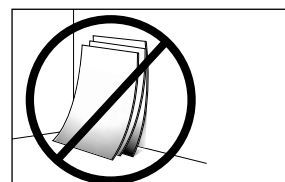

### Correct

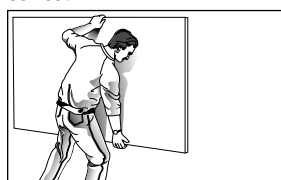

### Incorrect



## Preparation

### Crawl Space Requirements

Ground area under crawl space must be covered with an adequate vapour barrier (minimum 4 mil.). Wood subfloors must have a minimum 450 mm (18") of well-ventilated space between ground level and joists.

Crawl-space requirements may vary based on geographic location. Consult local building codes for more specific information.

### Furnaces

Do not use FIBEROCK Brand Underlayment in areas subject to continuous localized temperatures above 52°C (125°F). Near furnaces or hot air ducts, use 50mm (2") thick insulation between the heat source and the subfloor between the floor joists (check your local building code).

### Existing Vinyl Floor

When installing underlayment over an existing vinyl floor, be sure to prepare the surface using the following steps. Do not install FIBEROCK Brand Underlayment over heavily cushion-backed, thick foam backed, or perimeter-fastened vinyl floor coverings.

- 1 Make sure that back of existing vinyl covering is fully adhered and bonded.
- 2 Repair any missing or broken tiles, curling seams, severe gouges, or protrusions by filling with floor leveler.

### Wood Subfloor

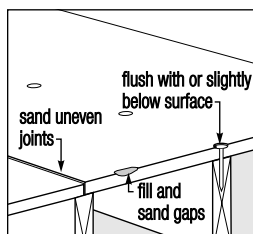

- 1 Sand all uneven subfloor joints.
- 2 Reset any protruding fasteners. All fasteners should be flush with or slightly below the subfloor surface.
- 3 Fill any subfloor voids or depressions with patching compound. Floor must be level and well-secured.
- 4 Remove all debris from subfloor and vacuum carefully to eliminate excess dust and dirt.
- 5 Make sure floor is dry (maximum 15% moisture) before installing underlayment. Excess moisture will cause underlayment joints to show through floor covering.

## Installation

### Cutting FIBEROCK Brand Panels

For most cuts, use the "score-and-snap" method. Score one side of the panel twice with utility knife, then snap upward along the score line. Smooth rough edges with rasp.

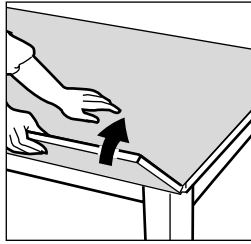
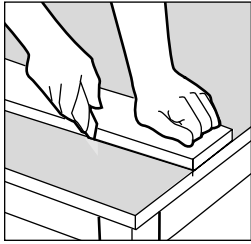

For more difficult cuts, combine the "score-and-snap" method with use of a handsaw or low rpm power saw. To cut holes in panels (for plumbing, etc.) use a holesaw, keyhole saw, or variable speed jigsaw.

The diagrams below show some combinations of methods and tools that might be used for different cutting situations.

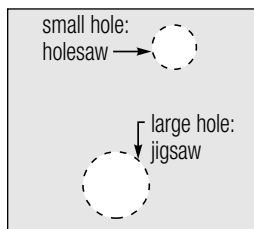
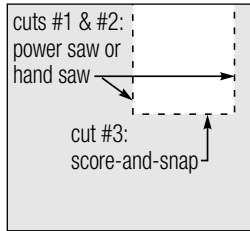
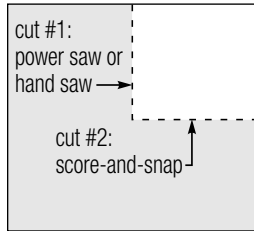

### Placing FIBEROCK Brand Panels

- 1 Place panels smooth side up immediately before laying the finish floor. Avoid construction traffic and abuse. Panels should be installed at normal room temperature and humidity conditions.
- 2 Beginning in the corner of the room, place panels at right angles to the subfloor panels.
- 3 Lay panels so that cut edges are against the wall, with factory edge meeting factory edge (see diagram). Leave a 6-10 mm (1/4"-3/8") space between panel and wall to allow for expansion.
- 4 Lightly butt panels together; do not force. The gap between panels should be no more than 1 mm (1/32").
- 5 Offset joints 200 mm-300 mm (8"-12") from the subfloor joints.
- 6 Stagger the joints a minimum 400 mm (16") o.c. so that four panel corners never meet.

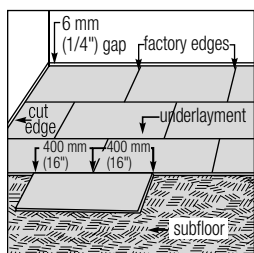

### Fastening FIBEROCK Brand Panels

It is important that you choose the right fasteners and follow proper application procedures when installing underlayment. Improper fastening of underlayment panels is one of the primary factors in joint and fastener-head show-through in vinyl flooring.

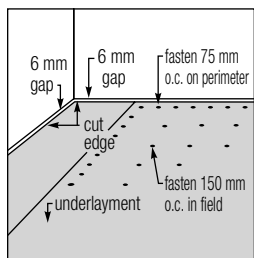

- 1 Ensure that the subfloor is dry (maximum 15% moisture).
- 2 Use ring-shanked underlayment nails or chisel-point staples with a 6mm (1/4") crown [16-gauge] for attachment. Avoid resin-, rosin-, and cement-coated fasteners that can discolour vinyl flooring.
- 3 Hold panels flat and in tight contact with the subfloor while fastening. When using a pneumatic tool, apply pressure on the gun to hold the panel tightly to the subfloor before shooting the fastener in. Do not hold the trigger and bounce the tool.

- 4 Install cut edges against the wall. Only factory edges should be joined.
- 5 Minimize fastener penetration through the subfloor. Leg length should be approximately equal to the combined thickness of the underlayment and subfloor.
- 6 Follow the fastener pattern on the panel face, spacing fasteners as follows:
  - 12 mm (1/2") from the panel edge;
  - every 50 mm (2") or less around the perimeter; and
  - 100 mm (4") in the field.
- 7 Make sure that fasteners are flush with or slightly below the underlayment surface. Avoid counter sinking too deeply, which can cause movement off of the subfloor, resulting in joint show through.
- 8 Fasten one panel at a time. Begin at one end and fan out across the panel.  
*Do not tack corners.*

### Finishing Joints in FIBEROCK Brand Underlayment

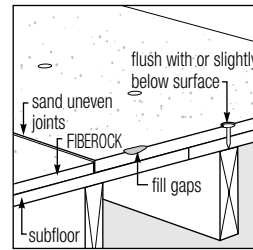

Fastener length should equal thickness of floor.

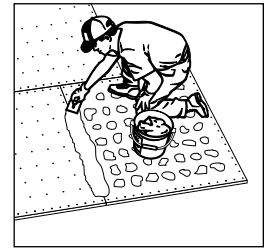

- 1 Sand uneven panel joints until they are smooth and even. If you cannot feel the seam, sanding is not required.
  - 2 Apply leveling/patching compound to gaps, gouges, and chips to create a smooth, level surface between adjacent panels. Fasteners may require compound if they are not smooth to the touch.
  - 3 Apply leveling/patching compound to the joints between panels to create a smooth, level surface. This may require more than one coat. Use an approved patching compound recommended by the vinyl floor manufacturer.
  - 4 Allow compound to dry; sand again until smooth.
  - 5 Remove all debris from underlayment; vacuum carefully to eliminate excess dust and dirt.
- You can now install your floor covering, carefully following the manufacturer's instructions. Allow 24 hours after floor covering installation before placing heavy appliances or furniture on floor.

### Panel Attachment – For Ceramic Tile

- 1 **Lamination:** Laminate FIBEROCK Brand Underlayment to minimum 16 mm (5/8") thick exterior grade plywood using Type 1 organic adhesive, latex portland cement mortar, or dry set mortar. Apply adhesive with 5 mm (5/32") V-notched trowel, mortar with 6 mm (1/4") square-notched trowel.
- 2 **Fasteners:** Place underlayment with joints staggered from subfloor joints. Fit ends and edges closely but not forced together. Fasten underlayment to subfloor using hot-dipped ring-shanked underlayment nails or screws. Fasteners should be spaced 200 mm (8") o.c.
- 3 **Joint Treatment:** Sand uneven panel joints. Prefill all joints with tile-setting mortar or adhesive, and then immediately embed DUROCK Brand Interior Tape over the joints. Strike joints flush. Additional fill coats may be required.
- 4 **Ceramic Tile Installation: Note** - Refer to ANSIA108.4 or A108.5 for complete tile installation instructions. Refer to mortar, tile, and grout manufacturer's recommendations for proper tile type and size; mixing instructions; and set and cure times. Spread mortar with a notched trowel. Set tile units into place with a twisting motion.

### Panel Attachment – Countertops

- 1 **Attachment:** Install minimum 19 mm (3/4") exterior-grade plywood base across the wood cabinet supports, spaced a maximum of 400 mm (16") o.c. Position ends and edges over supports. Staple-attach 15 lb. felt or 4-mil polyethylene film using 6 mm (1/4") galvanized staples over the plywood base. Laminate underlayment to the membrane with latex-fortified mortar using a 6 mm (1/4") square notched trowel. Fastened to the plywood with hot-dipped ring-shanked underlayment nails or DUROCK Brand wood screws, spaced 200 mm (8") o.c. in both directions and around edges; or with 6 mm (1/4") x 22 mm (7/8") galvanized staples spaced 100 mm (4") o.c. in both directions around edges.

### Panel Attachment – For Wood Flooring

- 1 **Mechanically Fastened Wood Flooring:** When mechanically fastening wood flooring, fasteners must be long enough to penetrate through the FIBEROCK Brand Underlayment and into the subfloor. The length of the fasteners should be determined by adding the thickness of the underlayment to the length of the fastener recommended by the flooring manufacturer. Follow the recommendations provided above under "Fastening FIBEROCK Brand Panels for Vinyl Floor Covering" for underlayment installation.
- 2 **Glued-Down Wood Flooring:** Glue-down installation of engineered or solid hardwood flooring must be done in strict accordance with the manufacturer's installation instructions. Follow the recommendations provided above under "Fastening FIBEROCK Brand Panels for Vinyl Floor Covering" for underlayment installation.